

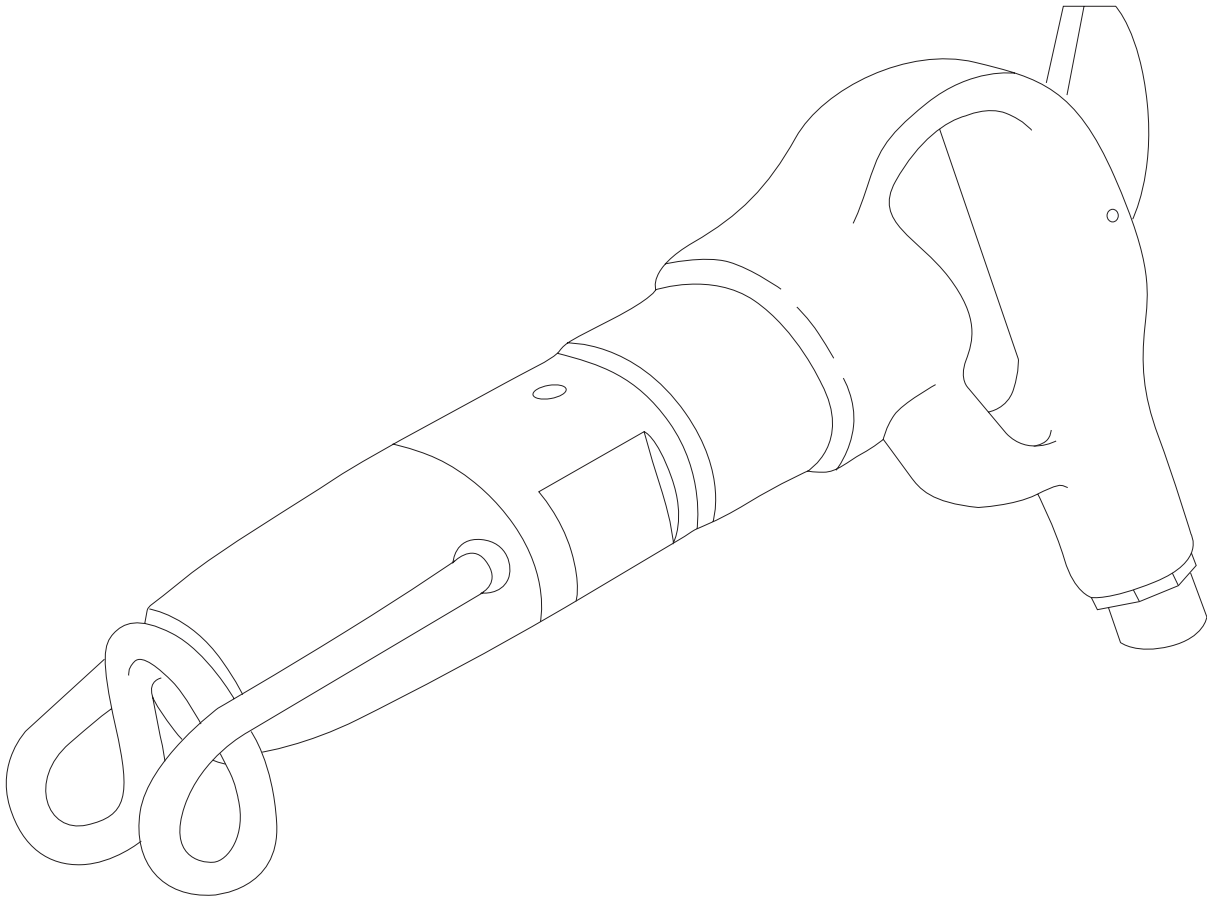

Ingersoll-Rand®

OPERATION AND MAINTENANCE IR2PS, IR3PS AND IR5PS MODELS



**This manual contains
important safety information
and must be made available
to personnel who operate and
maintain this machine**



**CPN: 22113542
DATE: APRIL 2002**

PORTABLE POWER PRODUCT WARRANTY

Ingersoll-Rand, through its distributor, warrants that each item of equipment manufactured by it and delivered hereunder to the initial user will be free of defects in material and workmanship for a period of three (3) months from initial operation or six (6) months from the date of shipment to the initial user, whichever occurs first.

With respect to the following types of equipment, the warranty period enumerated below will apply in lieu of the foregoing warranty period.

- A. Aftercoolers** – The earlier of nine (9) months from date of shipment to or six (6) months from initial operation by initial user.
- B. Portable Compressors, Portable Generator Sets – 9 Kva through to 550 Kva, Portable Light Towers and Air Dryers** – The earlier of twelve (12) months from shipment to or the accumulation of 2,000 hours of operation by the initial user.
2.5 Kva Through to 8 Kva – The earlier of twelve (12) months from shipment to or the accumulation of 2,000 hours of operation by the initial user.
Ingersoll-Rand will provide a new part or repaired part, at its sole discretion, in place of any part which is found to be defective in material or workmanship during the period described above. Labour cost to replace the part is the responsibility of the initial user.
- C. Portable Compressor Air Ends** – The earlier of twenty-four (24) months from shipment to or the accumulation of 4,000 hours of operation by the initial user. For Air Ends, the warranty against defects will include replacement of the complete Air End, provided the original Air End is returned assembled and all original seals are intact.
- D. Portable Compressor Airend Limited Extended Warranty** – The earlier of sixty (60) months from shipment to or the accumulation of 10,000 hours of operation by the initial user. This extended warranty is limited to defects in design or defective material or workmanship in rotors, housings, bearings and gears and provided all the following conditions are met:
 - 1. The original air end is returned assembled and all original seals are intact.
 - 2. Continued use of genuine Ingersoll-Rand parts, fluids, oil and filters.
 - 3. Intervals by authorised and properly trained service engineers.
- E. Generator Alternator – 9 Kva through to 550 Kva**, the earlier of twenty-four (24) months from shipment to or the accumulation of 4,000 hours of operation by the initial user.
2.5 Kva Through to 8Kva – The earlier of twelve (12) months from shipment to or the accumulation of 2,000 hours of operation by the initial user.
- F. Portable Light Tower Alternator** – The earlier of twelve (12) months from shipment to or the accumulation of 2,000 hours of operation by the initial user. Light Source model only, the earlier of twenty-four (24) months from shipment to or the accumulation of 4,000 hours of operation by the initial user.
- G. Ingersoll-Rand Engines** – The earlier of twenty-four (24) months from shipment to or the accumulation of 4,000 hours of operation by the initial user.
- H. Ingersoll-Rand Platinum Drive Train Limited Extended Warranty** – Platinum drive train refers to the Ingersoll-Rand Engine and Airend combination.

The earlier of sixty (60) months from shipment to, or the accumulation of 10,000 hours of operation by the initial user. The starter, alternator, fuel injection system and all electrical components are excluded from this extended warranty. The airend seal and drive coupling are included in the warranty but airend drive belts are excluded. This limited extended warranty is automatically available when meeting the following conditions:

- 1. The original airend is returned assembled and unopened.
 - 2. Continued use of genuine Ingersoll-Rand parts, fluids, oil and filters.
 - 3. Maintenance is performed at prescribed intervals by authorised and properly trained service engineers.
- I. 1. Construction Tools, (Portable Power range only)** – Twelve months from shipment to initial user. Ingersoll-Rand will provide a new part or repaired part, at its sole discretion, in place of any part which is found to be defective in material or workmanship during the period described above. Labour cost to replace the part is the responsibility of the initial user.
 - 2. Construction Tools Limited Extended Warranty, (Portable Power range only)** – Thirty-six (36) months from shipment to initial user. This extended warranty is automatically available only when the tool is registered with Ingersoll-Rand by completing and submitting the Warranty Registration form. Ingersoll-Rand will provide a new part or repaired part, at its sole discretion, in place of any part which is found to be defective in material or workmanship during the period described above. Labour cost to replace the part is the responsibility of the initial user.
- J. Spare Parts** – Six (6) months from date of shipment to the initial user. Ingersoll-Rand will provide a new part or repaired part, at its sole discretion, in place of any part that is found to be defective in material and workmanship during the period described above. Such parts will be repaired or replaced without charge to the initial user during normal working hours at the place of business of an Ingersoll-Rand distributor authorised to sell the type of equipment involved or other establishment authorised by Ingersoll-Rand. User must present proof of purchase at the time of exercising warranty. The above warranties do not apply to failures occurring as a result of abuse; misuse, negligent repairs, corrosion, erosion and normal wear and tear, alterations or modifications made to the product without express written consent of Ingersoll-Rand; or failure to follow the recommended operating practices and maintenance procedures as provided in the products operating and maintenance publications.

Accessories or equipment furnished by Ingersoll-Rand, but manufactured by others, including, but not limited to, engines, tires, batteries, engine electrical equipment, hydraulic transmissions, carriers, shall carry only the manufacturers warranty, which Ingersoll-Rand can lawfully assign to the initial user.

THE ABOVE WARRANTIES ARE IN LIEU OF ALL OTHER WARRANTIES EXPRESSED OR IMPLIED, (EXCEPT THAT TO TITLE, AND THERE ARE NO WARRANTIES OF MERCHANT ABILITY OR OF FITNESS FOR A PARTICULAR PURPOSE.

Machine models represented in this manual may be used in various locations world-wide. Machines sold and shipped into European common market countries requires that the machine display the EC Mark and conform to various directives. In such cases, the design specification of this machine has been certified as complying with EC directives. Any modification to any part is absolutely prohibited and would result in the CE certification and marking being rendered invalid. A declaration of that conformity follows:



DECLARATION OF CONFORMITY WITH EC DIRECTIVES

98/37/EC, 2000/14/EC

We

Ingersoll-Rand Company
 Portable Power Division P.O.
 Box 868
 501 Sandford Avenue
 Mocksville,
 North Carolina 27028
 USA

Represented in EC by

Ingersoll-Rand Company Ltd
 Portable Power Division
 Swan Lane
 Hindley Green
 Wigan WN2 4EZ
 United Kingdom

Declare that under our sole responsibility for manufacture and supply, the product(s)

Pickhammer Types IR2PS, IR3PS and IR5PS

To which this declaration relates, is (are) in conformity with the provisions of the above directives using the following principal standards

EN292, BSEN28662-5,

Issued at Mocksville on 1-4-2002

Issued at Hindley Green on 1-4-2002

Ric Lunsford
 Manager of Quality Control

Harry Seddon
 Quality Assurance Manager

CONFORMITY TO NOISE DIRECTIVE

2000/14/EC

Ingersoll-Rand Company Limited declare that the following Pickhammers have been manufactured in conformity with the directive as shown

Directive	Machine Model	Weight Range	Mean Measured Value	Guaranteed Level	Notified Body
2000/14/EC Annex VI Part 1	IR2PS	2.6kg	106L _{WA}	107L _{WA}	L.N.E Paris France
	IR3PS	3.5kg	107L _{WA}	107L _{WA}	
	IR5PS	5kg	107L _{WA}	107L _{WA}	

Harry Seddon
 Quality Assurance Manager

Issued at Hindley Green
 1st Declaration... 1-4-2002

Look for these signs on machines shipped to markets in North America, which point out potential hazards to the safety of you and others. Read and understand thoroughly. Heed warnings and follow instructions. If you do not understand, inform your supervisor.



DANGER

Red Background

Indicates the presence of a hazard which WILL cause serious injury, death or property damage, if ignored.



CAUTION

Yellow Background

Indicates the presence of a hazard which WILL or can cause injury or property damage, if ignored.



WARNING

Orange Background

Indicates the presence of a hazard which CAN cause serious injury, death or property damage, if ignored.

NOTICE

Blue Background

Indicates important set-up, operating or maintenance information.

NOTICE

IR2PS, IR3PS and IR5PS Pickhammers are designed for breaking concrete and other demolition work in construction applications.

Ingersoll-Rand is not responsible for customer modifications of tools for applications on which Ingersoll-Rand was not consulted.



WARNING

**IMPORTANT SAFETY INFORMATION ENCLOSED.
READ THIS MANUAL BEFORE OPERATING TOOL.**

**IT IS THE RESPONSIBILITY OF THE EMPLOYER TO PLACE THE INFORMATION
IN THIS MANUAL INTO THE HANDS OF THE OPERATOR.
FAILURE TO OBSERVE THE FOLLOWING WARNINGS COULD RESULT IN INJURY.**

PLACING TOOL IN SERVICE

- Always operate, inspect and maintain this tool in accordance with all regulations (local, state, federal and country), that may apply to hand held/hand operated pneumatic tools.
- For safety, top performance, and maximum durability of parts, operate this tool at 90 psig (6.2 bar/620 kPa) maximum air pressure at the inlet with 1/2" (13 mm) inside diameter air supply hose.
- Always turn off the air supply and disconnect the air supply hose before installing, removing or adjusting any accessory on this tool, or before performing any maintenance on this tool.
- Do not use damaged, frayed or deteriorated air hoses and fittings.
- Be sure all hoses and fittings are the correct size and are tightly secured.
- Always use clean, dry lubricated air at 90 psig (6.2 bar/620 kPa) maximum air pressure. Dust, corrosive fumes and/or excessive moisture can ruin the motor of an air tool.
- Do not lubricate tools with flammable or volatile liquids such as kerosene, diesel or jet fuel.
- Do not remove any labels. Replace any damaged labels.

USING THE TOOL

- Always wear eye protection when operating or performing maintenance on this tool.
- Always wear hearing protection when operating this tool.
- Keep hands, loose clothing and long hair away from rotating end of tool.
- Anticipate and be alert for sudden changes in motion during start up and operation of any power tool.
- Keep body stance balanced and firm. Do not overreach when operating this tool.
- Tool accessories may continue to impact briefly after throttle is released.
- Air powered tools can vibrate in use. Vibration, repetitive motions or uncomfortable positions may be harmful to your hands and arms. Stop using any tool if discomfort, tingling feeling or pain occurs. Seek medical advice before resuming use.
- Use accessories recommended by Ingersoll-Rand.
- This tool is not designed for working in explosive atmospheres.
- This tool is not insulated against electric shock.

NOTICE

The use of other than genuine Ingersoll-Rand replacement parts may result in safety hazards, decreased tool performance, and increased maintenance, and may invalidate all warranties. Repairs should be made only by authorised trained personnel. Consult your nearest Ingersoll-Rand Authorised Servicenter.

WARNING LABEL IDENTIFICATION



FAILURE TO OBSERVE THE FOLLOWING WARNINGS COULD RESULT IN INJURY.

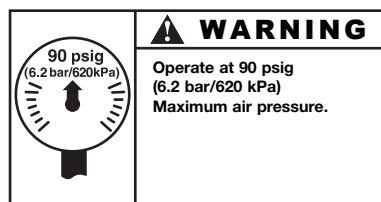
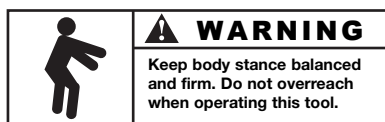
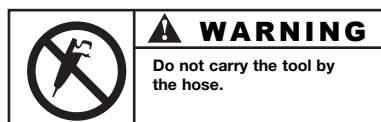
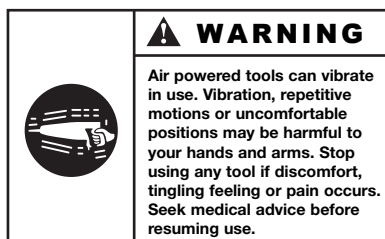
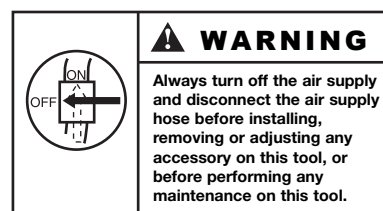
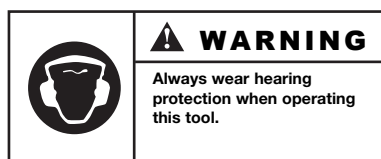
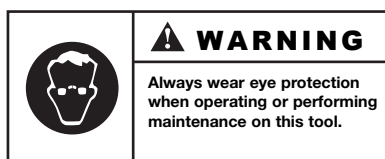

SPECIFIC WARNINGS

- When wearing gloves and operating models with inside trigger, always be sure that the gloves will not prevent the trigger from being released.
- Wear safety shoes, hard hat, safety goggles, gloves, dustmask and any other appropriate protective clothing while operating the tool.
- Do not indulge in horseplay. Distraction can cause accidents.
- Keep hands and fingers away from the throttle lever until it is time to operate the tool.
- Never rest the tool or chisel on your foot.
- Never point the tool at anyone.
- Compressed air is dangerous. Never point an air hose at yourself or co-workers.
- Never blow clothes free of dust with compressed air.
- Be sure all hose connections are tight. A loose hose not only leaks but can come completely off the tool and while whipping under pressure, can injure the operator and others in the area. Attach safety cables to all hoses to prevent injury in case a hose is accidentally broken.
- Never disconnect a pressurised air hose. Always turn off the air supply and bleed the tool before disconnecting a hose.
- The operator must keep limbs and body clear of the chisel. If a chisel breaks, the tool with the broken chisel projecting from the tool will suddenly surge forward.
- Do not ride the tool with one leg over the handle. Injury can result if the chisel breaks while riding the tool.
- Know what is underneath the material being worked. Be alert for hidden water, gas, sewer, telephone or electric lines.
- Use only proper cleaning solvents to clean parts. Use only cleaning solvents which meet current safety and health standards. Use cleaning solvents in a well-ventilated area.
- Do not flush the tool or clean any parts with diesel fuel. Diesel fuel residue will ignite in the tool when the tool is operated, causing damage to internal parts. When using models with outside triggers or throttle levers, take care when setting the tool down to prevent accidental operation.
- Do not operate the tool with broken or damaged parts.
- Never start the tool when it is lying on the ground.
- This tool is not designed for working in explosive atmospheres.
- This tool is not insulated against electric shock.

PLACING TOOL IN SERVICE

LUBRICATION



Always use an air line lubricator with these tools. Attach the lubricator as close to the tool as practical.

After each two or three hours of operation and at the beginning of each work shift, if an air line lubricator is not used, disconnect the air hose and pour about 3 cc of oil into the air inlet of the tool.

Before storing the tool or if the tool is to be idle for a period exceeding twenty-four (24) hours, pour about 3 cc of oil into the air inlet and operate the tool for 5 seconds to coat the internal parts with oil.

INSTALLATION

Air Supply and Connections

Always use clean, dry lubricated air. Dust, corrosive fumes and/or excessive moisture can ruin the motor of an air tool. An air line filter can greatly increase the life of an air tool. The filter removes dust and moisture.

Make sure all hoses and fittings are the correct size and are tightly secured.

OPERATION

Accessory Installation



WARNING

Always turn off the air supply and disconnect the air supply hose before installing, removing or adjusting any accessory on this tool or before performing any maintenance on this tool. Failure to do so could result in injury.

Retainer

1. Operate the Retainer until it is approximately 90 degrees to the body of the tool.
2. Insert the accessory into the tool.
3. Operate the Retainer until it is parallel to the tool and it clicks into position.

NOTICE

Do not repair the tool at the work site. Always take the tool to a repair shop. Never drag the tool on the ground. The air port and other openings will become clogged with dirt and debris.

CAUTION

Compressed air is dangerous. When blowing the line clear of dirt, wear eye protection and keep the air line directed toward a safe, clear area.

Always blow out the air line before using to clear the line of dirt.

CAUTION

Do not operate the tool unless the chisel is against the work since this will cause premature wear of parts.

Always break material to the point of "give". Cracking does not result in a complete break. Clear away rubble as it is broken since uncleared rubble blocks the point of "give".

Always take the right size "bite" with the tool. When working new material, experiment to find the right size "bite" required for breaking that material efficiently.

NOTICE

If "bites" are too big, the operator will try to pry with the tool. This could break the chisel. The tool is designed for demolition, not prying. Always use a pick for prying. If "bites" are too small, the operator will be working too slowly.

If the chisel or accessory should become stuck, do not use excessive force or mechanical means on the tool to pull out the chisel. Break out the stuck chisel with a spare chisel or tool.

MAINTENANCE SECTION



WARNING

Always wear eye protection when operating or performing maintenance on this tool.

Always turn off the air supply and disconnect the air supply hose before installing, removing or adjusting any accessory on this tool or before performing any maintenance on this tool.

DISASSEMBLY

General Instructions

1. Do not disassemble the tool any further than necessary to replace or repair damaged parts.
2. When grasping a tool or part in a vise, always use leather-covered or copper-covered vise jaws to protect the surface of the part and help prevent distortion. This is particularly true of threaded members and housings.
3. Do not remove any part which is a press fit in or on a subassembly unless the removal of that part is necessary for repairs or replacement.
4. Do not disassemble the tool unless you have a complete set of new gaskets and O-rings for replacement.
5. Clean the exterior of the Pickhammer before disassembly.
6. Provide a clean work area for disassembling the Pickhammer.
7. Handle all parts carefully. Hardened parts may chip or break if dropped on a hard surface.
8. Probe all porting to loosen and clean out all foreign matter. Place small parts in a clean box to prevent loss.

Disassembly of the Pickhammer

For IR3PS and IR5PS

1. Grasp the Handle (1) firmly in leather-covered or copper-covered vise jaws with the Cylinder (22) upward.

CAUTION

Do not exert extreme pressure on the Handle. The Handle can be cracked if the vise is tightened excessively.

2. Using a large adjustable wrench on the flats of the Cylinder, loosen the Cylinder.

NOTICE

Do not loosen the Cylinder unless a new O-ring (11) is available. This O-ring is usually damaged during disassembly.

3. Remove the Pickhammer from the vise and unscrew the Cylinder from the Handle.
4. **For Model IR3PS**, remove the Cylinder Spacer (12), Washer Guide (13), Spring Washer Assembly (15), Piston Shield (17) and Piston (21) from the Cylinder. **For Model IR5PS**, remove the Cylinder Spacer (12), Upper Valve Seat (14), Valve (18), Lower Valve Seat (19), Piston Bumper (16), two Valve Pins (20) and Piston (21) from the Cylinder.
5. Remove the O-ring from the Cylinder.
6. **For Model IR5PS**, press the Nozzle (23) from the Cylinder if the Nozzle requires replacement.
7. Using a wrench, remove the Inlet Bushing Assembly (10) from the Handle.
8. Remove the Throttle Valve Spring (9), Throttle Valve Pin (8), Throttle Valve Face (7) and the Throttle Valve Stem (6).
9. If the Throttle Valve Stem Bushing (5) requires replacement, press the Throttle Lever Pin (3) from the Handle and remove the Throttle Lever (2). Using an arbor press and a rod that fits into the throttle lever slot, press the Bushing out of the Handle through the Inlet Bushing opening.
10. If the Throttle Valve Stem Bushing (5) requires replacement, press the Throttle Lever Pin (3) from the Handle, and remove the Safety Throttle Lever (1A). Using an arbor press and a rod that fits into the throttle lever slot, press the Bushing out of the Handle through the Inlet Bushing opening.
11. If the Safety Lever (1B) requires replacement, press the Safety Lever Pin (1C) from the Handle, and remove the Safety Lever and the Safety Lever Spring.

For IR2PS

1. Grasp the Handle (1) firmly in the leather-covered or copper-covered vise jaws with Cylinder (19) upward.

CAUTION

Do not exert extreme pressure on the Handle. The Handle can be cracked if the vise is tightened excessively.

2. Remove the Retainer (29).
3. Remove the Deflector (28) from the Cylinder.
4. Remove the Handle Pin (25).
5. Using a large adjustable wrench on the flats of the Cylinder, loosen the Cylinder.

MAINTENANCE SECTION

6. Remove the Pickhammer from the vise and unscrew the Cylinder from the Handle.
7. Remove the Spacer Rings (30), Valve (12), Valve Box (13), Valve Pin (18) and Piston (20) from the Cylinder.
8. Press the Nozzle (21) from the Cylinder if the Nozzle requires replacement.
9. Using a wrench, remove the Valve Stopper (7) from the Handle.
10. Remove the Throttle Valve Spring (6), Throttle Valve Face (4) and Throttle Valve Stem (8) from the Handle.
11. If the Inlet Bushing (10) requires replacement, remove the Inlet Bushing from the Handle by using a wrench.
8. Install the Inlet Bushing Seal (10A) on the Inlet Bushing (10) and thread the Inlet Bushing Assembly into the Handle and tighten it to 9 ft-lb (12 Nm) torque.
9. **For Model IR5PS**, press the new Nozzle (23) into the front end of the Cylinder (22) if the Nozzle required replacement.
10. Install the O-ring (11) in the groove adjacent to the threads on the exterior of the Cylinder.
11. Insert the Piston (21) into the rear end of the Cylinder.
12. **For Model IR3PS**, proceed as follows:
 - a. Install the Piston Shield (17) in the threaded end of the Cylinder with the shallow counterbored surface toward the Piston.
 - b. Stack the three Spring Washers (15) together and position them, concave side first, against the Piston Shield.
 - c. Insert the small diameter hub of the Washer Guide (13) into the central opening of the Spring Washers.
 - d. Position the Cylinder Spacer (12) against the threaded end of the Cylinder and thread the Handle onto the Cylinder.

ASSEMBLY

General Instructions

1. When grasping a tool or part in a vise, always use leather-covered or copper-covered vise jaws to protect the surface of the part and help prevent distortion. This is particularly true of threaded members and housings.
2. Always clean every part and wipe every part with a thin film of clean oil before installation.
3. Apply a film of O-ring lubricant to all O-rings before final assembly.
4. Except for press fits, parts should fit together easily. If force is required to assemble parts, the parts are out of alignment and must be correctly aligned to prevent binding and damage.

Assembly of the Pickhammer

For IR3PS and IR5PS

1. If the Throttle Valve Stem Bushing (5) was removed, press a new Bushing into the Handle (1).
2. Position the Throttle Lever (2) in the Handle and secure it by pressing the Throttle Lever Pin (3) into the Handle and through the Throttle Lever.
3. If the Safety Lever (1B) was removed, position the Safety Lever and the Safety Lever Spring (1D) in the Handle, with the "U"-shape of the Spring inside the angle made by the Safety Lever. Secure them by pressing the Safety Lever Pin (1C) into the Handle, and through the Safety Lever and Spring.

NOTICE

Safety system is to be fitted only with adapted Safety Throttle Lever (1A).

4. Position the Safety Throttle Lever in the Handle, adjusting the "L"-shape of the Safety Lever Spring against the edge of the Throttle Lever. Secure it by pressing the Throttle Lever Pin (3) into the Handle, and through the Safety Throttle Lever.
5. Insert the Throttle Valve Stem (6) into the Throttle Valve Stem Bushing.
6. Position the slotted end of the Throttle Valve Face (7) against the Throttle Valve Stem.
7. Install the smaller diameter end of the Throttle Valve Spring (9) on the short hub of the Throttle Valve Pin (8). Using the Spring to hold the Pin, install the long end of the Throttle Valve Pin into the Throttle Valve Face.

For Model IR5PS, proceed as follows:

- a. Insert the two Valve Pins (20) into the holes in the threaded end of the Cylinder.
 - b. If the Piston Bumper (16) was separated from the Lower Valve Seat (19) during disassembly, work the large diameter of the Piston Bumper into the counterbore of the Lower Valve Seat until the Bumper is seated squarely against the Valve Seat.
 - c. Slide the Lower Valve Seat, Piston Bumper first, onto the two Pins and against the Cylinder.
 - d. Position the Valve (18) in the counterbore of the Upper Valve Seat (14) and slide the Upper Valve Seat, Valve first, onto the Pins against the Lower Valve Seat.
 - e. One or two Cylinder Spacers (12) have been installed in these tools at the factory to locate the Handle in the correct position at the Cylinder. Install an identical number of Spacers of the same thickness (1 or 2 mm thick) in the rear of the Handle with the dished side of the Spacer facing the Valve.
 - f. Thread the Handle onto the Cylinder.
13. Using a torque wrench, tighten the Cylinder between 46 and 54 Nm (34 and 40 lbs.ft) torque.

MAINTENANCE SECTION

For IR2PS

1. If the Throttle Lever (2) was removed, position the Throttle Lever into the Handle (1) and secure it by pressing the Throttle Lever Pin (3) into the Handle and through the Throttle lever.
2. Insert the Throttle Valve Stem (8) into the Throttle Valve Stem Bushing (9).
3. Position the cone end of the Throttle Valve Face (4) against the Throttle Valve Stem.
4. Install one end of the Throttle Valve Spring (6) into the Throttle Valve Face (4).
5. Install the Valve Stopper (7) on the other end of the Throttle Valve Spring, and thread it into the Handle and tighten it to 12 Nm (9 lbs.ft) torque. Also, thread the Inlet Bushing (10) into the Handle if it was removed.
6. Press the new Nozzle (21) into the front end of the Cylinder (19) if the Nozzle required replacement.
7. Insert the Piston (20) into the rear end of the Cylinder.
8. Install the Valve Pin (18) into the smallest of the four holes located into the rear of the Cylinder.
9. Slide the Valve Box (13) into the rear of the Cylinder, its larger surface first, and position it on the Valve Pin.
10. Then, slide the Valve (12) into the Valve Box (13), its smallest diameter first.
11. One of two Spacer Rings (30) have been installed in these tools at the factory to locate the Handle in the correct position at the Cylinder. Install an identical number of Spacer Rings of the same thickness (1 or 1.5 mm thick) in the rear of the Handle with the dished side of the Spacers facing the Valve.
12. Using a torque wrench, tighten the Cylinder between 46 and 54 Nm (34 and 40 lbs.ft) torque.
13. Position the Handle Pin (25) into the only hole of the Cylinder that faces exactly one slot of the Handle.
14. Slide the Deflector (28) on the Cylinder, and position it into the slots of the Handle.
15. Install the Retainer (29) into the two side holes of the nose of the Cylinder.

MAINTENANCE SECTION

TROUBLESHOOTING GUIDE		
Trouble	Probable Cause	Solution
Pickhammer will not start	<p>Plugged exhaust port or air passages caused by dirt or hose particles</p> <p>Stuck valve due to gummy oil or incorrect assembly</p> <p>Frozen piston due to improper lubrication</p>	<p>Dismantle the Pickhammer and clean out all ports and air passages. Keep the air hose in top notch condition; never use a soft, deteriorated hose.</p> <p>Remove and clean the valve chest parts. Never use dirty oil or oil that does not conform to the recommended specifications. Check for correct valve assembly procedures.</p> <p>Repair the piston by placing in a high speed lathe and dressing with fine emery cloth. Never run the Pickhammer without the proper lubricating oil in the lubricator.</p>
Pickhammer loses power rapidly	<p>Restriction in the air hose</p> <p>Air hose too long</p> <p>Air Hose diameter too small</p> <p>Clogged Inlet Bushing screen</p>	<p>Never allow the air hose to kink or make sharp bends.</p> <p>As a general rule, keep the air hose length under 15 m (49 ft).</p> <p>Use a 13 mm (1/2") inside diameter air supply hose.</p> <p>Clean the screen in the Inlet Bushing Assembly</p>
Pickhammer lacks power	<p>Low air supply pressure</p> <p>Running on Fronthead cushion</p> <p>Plugged air passages</p> <p>Lack of lubricating oil</p> <p>Clogged Inlet Bushing Screen</p>	<p>The maximum air supply pressure at the tool should be 6.2 bar (90 psig).</p> <p>Keep shank fed-up to the work. Always maintain a constant pressure when operating the Pickhammer.</p> <p>Disassemble the Pickhammer and clean out all ports and passages.</p> <p>Maintain the proper oil level in the lubricator. Steel shank must show a film of oil.</p> <p>Clean the screen in the Inlet Bushing Assembly.</p>
Cylinder overheating on new Pickhammer	<p>Tool not properly broken in</p>	<p>Stop operating the tool and perform initial servicing. Never run a new Pickhammer at full throttle until a proper break-in period has been completed.</p>
Tool overheating after break-in period	<p>Running on Fronthead cushion</p> <p>Piston not hitting shank because shank is short</p> <p>Pulling steel at full throttle</p> <p>Lack of lubricant or improper lubricating oil</p>	<p>Keep shank fed-up to the work. Always maintain a constant pressure when operating the Pickhammer.</p> <p>Remove the shank from the Pickhammer</p> <p>Use minimum throttle when pulling steels away from work.</p> <p>Before operating the Pickhammer, make sure the lubricating oil reservoir is full of proper lubricant.</p>
Erratic or sluggish operating	<p>Lubricating oil too heavy, slowing down valve action</p> <p>Gummed oil or dirt in operating parts</p> <p>Clogged Inlet Bushing screen</p>	<p>Use only the recommended lubricating oil.</p> <p>Disassemble the tool and clean out dirt and gummy residue. Service the Pickhammer with clean oil. Protect the tool from dirt when idle.</p> <p>Clean the screen in the Inlet Bushing Assembly.</p>
Freezing at exhaust ports	<p>Excessive moisture in the air supply line (Usually occurs in low ambient temperatures)</p>	<p>Install moisture traps in the air supply line or add anti-freeze lubricant directly through the air inlet. Use anti-freeze lubricant.</p>
Fogging	<p>Excessive moisture in the air supply line</p> <p>Over lubrication</p>	<p>Clean out the air lines. IF moisture traps are installed in the air supply line, drain the moisture.</p> <p>Adjust the lubricator for the proper rate lubricant feed.</p>

NOTICE

SAVE THESE INSTRUCTIONS. DO NOT DESTROY.

PLACING TOOL IN SERVICE

Models IR2PS, IR3PS and IR5PS Pickhammers are designed for breaking concrete and other demolition work in construction applications.

HOW TO ORDER A PICKHAMMER			
Model	Impacts/min.	Piston Stroke	
		in	mm
IR2PS	2850	2	50
IR3PS	3850	1-1/2	37
IR5PS	2550	2-3/8	60

MODEL IR2PS PICKHAMMER

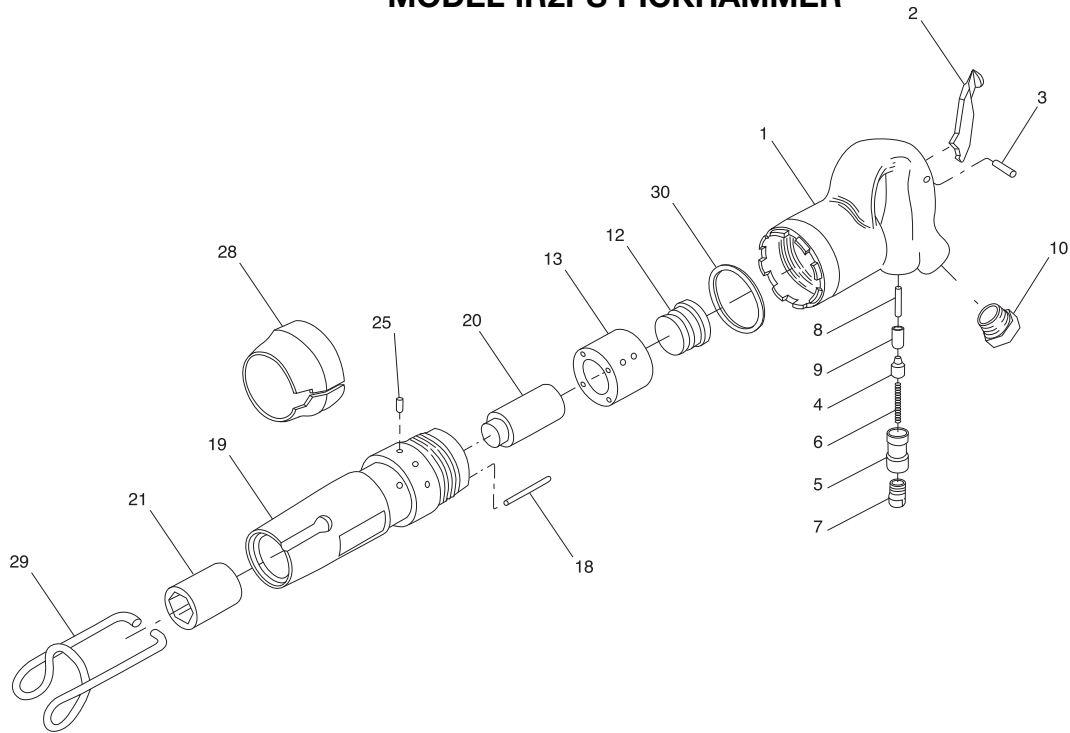

(Dwg. TPB996)

	CPN	PART NO. FOR ORDERING		CPN	PART NO. FOR ORDERING
1 Grip Handle.....	-	PH2-50901	• 18 Valve Pin	88099239	PH2-50918
2 Throttle Lever	88100904	PH2-50902	19 Cylinder	21867353	PH2-50919
• 3 Throttle Lever Pin.....	88098249	PH2-50903	20 Piston	56752041	PH2-50920
• 4 Throttle Valve Face	88099171	PH2-50904	21 Nozzle.....	21867346	PH2-50921
5 Throttle Valve Seat	88099189	PH2-50905	25 Handle Lock Pin	88099247	PH2-50925
• 6 Throttle Valve Spring	88099197	PH2-50906	28 Deflector.....	88098652	PH2-50928
7 Valve Stopper	88099205	PH2-50907	29 Retainer	88102116	PH2-50929
• 8 Throttle Valve Stem	88099213	PH2-50908	• 30 Spacer Ring		
9 Throttle Valve Stem Bush	88099221	PH2-50909	1 mm	88098702	PH2-50930
10 Inlet Bushing.....	88100912	PH2-50910	1.5 mm	56746910	PH2-50931
• 12 Valve.....	88100938	PH2-50912			
13 Valve Box	25012543	PH2-50913	* Nameplate	22112981	-

• Indicates Tune-Up Kit Part
* Not Illustrated

MODELS IR3PS AND IR5PS PICKHAMMERS

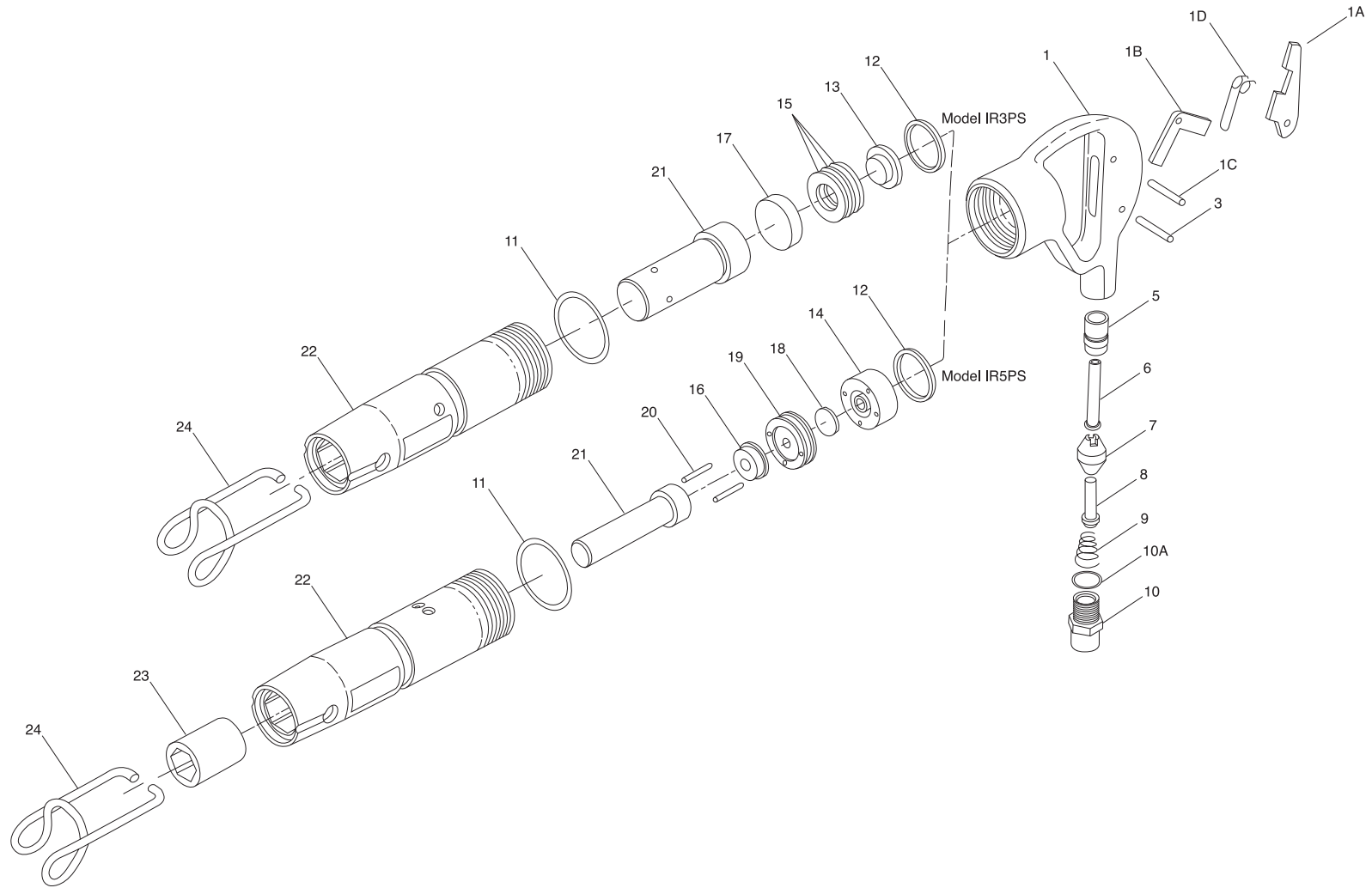

MAINTENANCE SECTION

	IR3PS (PART NO. FOR ORDERING)	CPN	IR5PS (PART NO. FOR ORDERING)	CPN
Grip Handle Assembly	PH3-50111	03764206	PH5-50202	03764396
1 Grip Handle	PH3-50110	03764214	PH5-50201	03764404
1A Safety Throttle Lever.....	PH3-50130	93483279	PH5-50130	56746654
1B Safety Lever	PH3-50131	93483287	PH5-50131	56746662
1C Safety Lever Pin.....	PH3-50132	93483295	PH5-50132	56750573
1D Safety Lever Spring	PH3-50133	93483303	PH5-50133	56748080
2 Throttle Lever	PH3-50101	03764222	PH3-50101	03764222
• 3 Throttle Lever Pin	PH3-50102	03764230	PH3-50102	03764230
5 Throttle Valve Stem Bushing.....	PH3-50104	03764248	PH3-50104	03764248
• 6 Throttle Valve Stem	PH3-50105	03764263	PH3-50105	03764263
• 7 Throttle Valve Face	PH3-50106	03764271	PH3-50106	03764271
• 8 Throttle Valve Pin.....	PH3-50107	03764289	PH3-50107	03764289
• 9 Throttle Valve Spring	PH3-50108	03764297	PH3-50108	03764297
10 Inlet Bushing Assembly	PH3-50127	03768835	PH3-50127	03768835
• 10A Inlet Bushing Seal	PH3-50128	03768843	PH3-50128	03768843
• 11 O-ring	PH3-50112	03764313	PH5-50203	03764503
• 12 Cylinder Spacer				
1 mm thick.....	-	-	PH5-50204	03764511
2 mm thick.....	-	-	PH5-50223	03768868
3.6 mm thick	PH3-50126	03768850	-	-
13 Washer Guide	PH3-50115	03764347	-	-
14 Upper Valve Seat	-	-	PH5-50205	03764529
15 Spring Washer Assembly (set of 3 Washers).....	PH3-50116	03764354	-	-
16 Piston Bumper	-	-	PH5-50209	03764560
17 Piston Shield	PH3-50117	-	-	-
• 18 Valve	-	-	PH5-50206	03764537
19 Lower Valve Seat.....	-	-	PH5-50207	03764545
• 20 Valve Pin (2)	-	-	PH5-50208	03764552
21 Piston	PH3-50118	03764370	PH5-50210	03764578
22 Cylinder	PH3-50113	03764321	PH5-50211	03764586
23 Nozzle	-	-	PH5-50212	03764594
24 Retainer	PH3-50114	03764339	PH3-50114	03764339
* Nameplate	-	22112999	-	22113005
* Tune-up Kit (includes illustrated parts 3, 6, 7, 8, 9, 10A and 11)....	PH3-TK1	-	-	-
(includes illustrated parts 3, 6, 7, 8, 9, 10A, 11, 12, 18 and 20 [2]) ..	-	-	PH5-TK1	-

• Indicates Tune-up Kit part.

* Not illustrated.

SPECIFICATIONS FOR IR2PS, IR3PS AND IR5PS PICKHAMMERS

Model	Chuck Size	Cpn	Overall Length mm (in)	Overall Width mm (in)	Weight Kg (lbs)	Max Working Pressure Bar (psi)	Air Consumption M ³ /min @ 6 Bar (CFM)
IR2PS	15R/12 hex x55	93482990	300 (12)	60 (2.4)	2.6 (5.7)	6.2 (90)	0.11 (4)
IR3PS	19 hex x50	01338060	335 (13.2)	60 (2.4)	3.5 (7.7)	6.2 (90)	0.11 (4)
IR5PS	19 hex x50	01337674	408 (16.6)	60 (2.4)	5.0 (11.0)	6.2 (90)	0.14 (5)

Model	Certified Vibration Level M/s ² @ 6 bar	Certified Noise Level L _{WA}	Impact Frequency /min	Handle /Cylinder Torque Nm (lbs.ft)	Air inlet Connector Torque Nm (lbs.ft)	Air Connection
IR2PS	6.95	107	2850	50 (37)	12 (9)	3/8" BSPP Female thread
IR3PS	2.93	107	3850	50 (37)	12 (9)	1/2" BSPP Male thread
IR5PS	6.67	107	2650	50 (37)	12 (9)	1/2" BSPP Male thread



Ingersoll – Rand Company
Portable Power Division P.O. Box 868
501 Sandford Avenue
Mocksville,
North Carolina 27028
USA

Ingersoll – Rand Company Ltd
Portable Power Division
Swan Lane
Hindley Green
Wigan WN2 4EZ
United Kingdom

www.portablepower.irco.com